

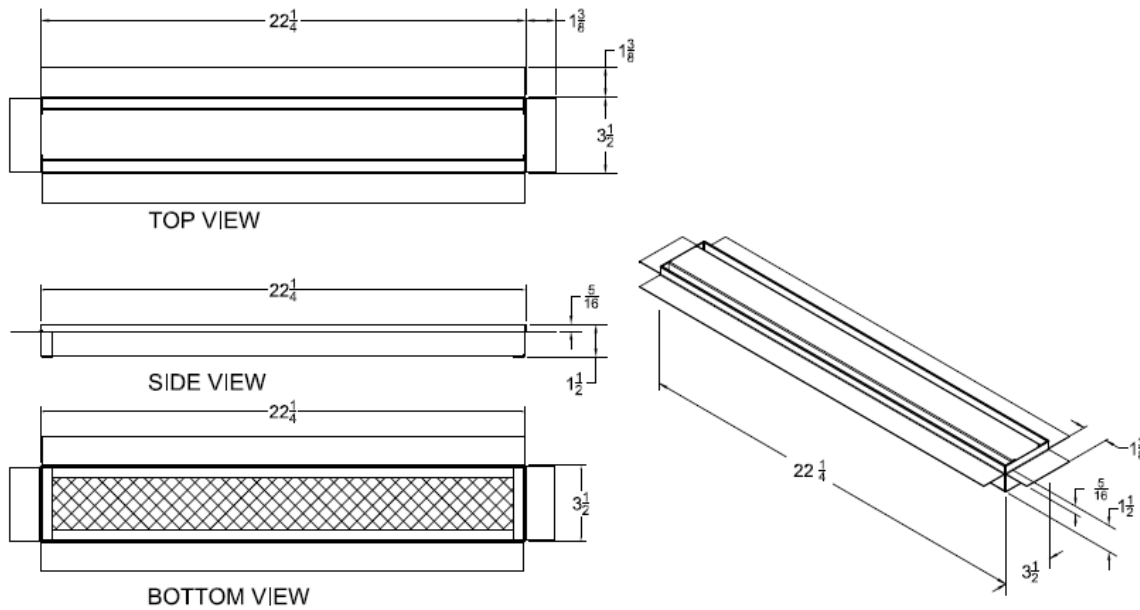

3.5" x 22" Soffit Vent Model # UE2011-H



Soffit Vents	Model	Size W x L	NFVA Provided	Flanges Available	Flange Definition	Weight
	UE2011-H	3.5" x 22"	20	Hardi/Fiber Cement	5/16" Setback	5lbs
Continuous Soffit and Custom sizes/materials AVAILABLE						

BENEFITS:

- Safety vents that are used in areas prone to wildfires, wind driven rain, or winddriven snow.
- Overlapping Baffle Protection (Patented)
 - Air Flows through normally
 - Resists the intrusion of Flame and Embers, Wind Driven Rain and Wind Driven Snow
- Approved for use throughout California and beyond
- Anti -Clogging Overlapping Baffles plus 1/8" mesh on back side of vent
- Prevents Rodent Entry
- 20 Year FULL Warranty
- Easy to Install and Paint

STANDARD MATERIALS

ASTM A653/A653M- G90 hot dipped galvanized steel, 26GA
 ASTM D9092- mill phosphatized coating for painting. IF BONDERIZED
 ASTM b370- Sheet Copper, 16oz and 20oz IF GALVANIZED
 .025 x.025 hot dipped galvanized 23ga wire mesh

Installation:

Install like any other similar Ventilator Product on the market.