

## 5.5" x 120" Soffit Vent Model # CS2021-FF

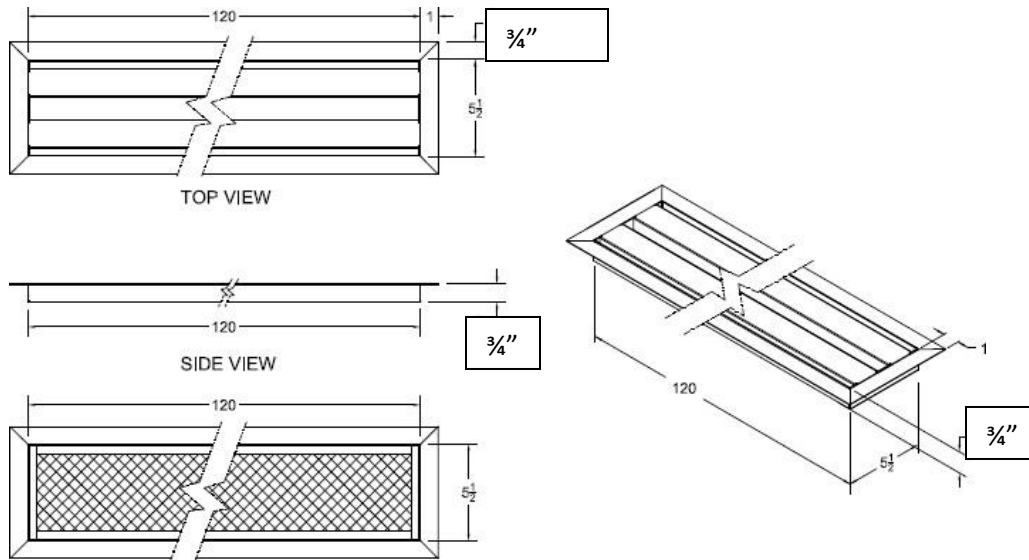

Soffit Vents	Model	Size W x L	NFVA Provided (sq in)	Flanges Available	Flange Definition	Weight
	CS2021-FF	5.5" x 120"	177	Flange Front	1" flange front	15lbs
Custom sizes/materials AVAILABLE						

### BENEFITS:

- Safety vents that are used in areas prone to wildfires, wind driven rain, or wind driven snow.
- Overlapping Baffle Protection (Patented)
  - Air Flows through normally
  - Resists the intrusion of Flame and Embers, Wind Driven Rain and Wind Driven Snow
- California State Fire Marshal- BML Approval # 8165-2232:0502
- **Compliant with ASTM E2886/2912 Tests** for flames, embers and radiant heat
- Triple protection: Anti -Clogging Overlapping Baffles, 1 hour fire rated E119 internal Intumescent Strips, plus 1/16" mesh on back side of vent
- Prevents Rodent Entry
- 20 Year Warranty
- Easy to Install, Retrofit and Paint

#### STANDARD MATERIALS

ASTM A653/A653M- G90 hot dipped galvanized steel, 26GA  
ASTM D9092- mill phosphatized coating for painting. IF BONDERIZED  
ASTM b370- Sheet Copper, 16oz and 20oz IF GALVANIZED  
hot dipped galvanized 23ga wire mesh

Installation: Install like any other similar Ventilator Product on the market.